

FRI-216-1-NMITS(S)-06

CONTROL OF AN INDUCTION MOTOR USING THE V/F METHOD

Assoc. Prof. Donka Ivanova, PhD

Faculty of Electrical Engineering, Electronics and Automation,
"Angel Kanchev" University of Ruse
Phone: 082-888 266
E-mail: divanova@uni-ruse.bg

Assoc. Prof. Anka Krasteva, PhD

Faculty of Electrical Engineering, Electronics and Automation,
"Angel Kanchev" University of Ruse
Phone: 082-888 659
E-mail: akrasteva@uni-ruse.bg

Assoc. Prof. Vyara Ruseva, PhD

Faculty of Electrical Engineering, Electronics and Automation,
"Angel Kanchev" University of Ruse
Phone: 082-888 659
E-mail: vruseva@uni-ruse.bg

***Abstract:** Induction motors are widely used in industry due to their low price, reliability and high efficiency. Methods for regulating the rotation frequency of induction motors are presented. Described is the principle of the V/f method and the main operation of the components used for its realization. The study is performed in Matlab/Simulink environment for a specific motor using a pulse-width modulator, an inverter, and a V/f ratio control unit. Results from MATLAB simulation for the engine's shaft rotation frequency and its electromagnetic moment are obtained.*

***Keywords:** Model, Simulink, induction motor, V/f control.*

INTRODUCTION

Induction motors are widely used in industry due to their low price, reliability and high efficiency (Akhila, E., Praveen Kumar, N., Isha, T.B., 2016; O. E. - S. Mohammed Youssef, 2018). It is of a great importance the speed of induction motors for domestic and industrial use to be controlled. When a load is applied, the actual speed differs from the reference speed. Therefore, for a particular usage it is very appropriate to maintain the actual speed and the reference speed at the same value after a change in the load (Eko J. Akpama, Iwara E. Omini, Emmanuel E. Effiong, Raymond U. Ezenwosu, 2020). There are many techniques known for controlling the speed of an induction electric motor - scalar and vector (Olarinoye A. G., C. Akinropo, G. J. Atuman and Z. M. Abdullahi, 2019; Varga, L., & Kuczmann, M., 2018). Many industrial applications work through scalar method for speed control. The V/f control method is used more frequently than other conventional methods for speed regulation due to its easy application and numerous advantages (Bharti R., M. Kumar and B. M. Prasad, 2019; Hussein, A. T., 2021).

The aim of the study is control of an induction motor through V/f method.

EXPOSITION

The variation of the rotation frequency of induction motors (IMs) is based on the dependence:

$$n = n_1(1 - s) = \frac{f}{p}(1 - s). \quad (1)$$

According (1) the rotation frequency can be regulated through change in: the number of the pairs of poles (p); the supply frequency (f); the slipping (s). When (p) or (f) are changed, the regulation is connected with change in the rotation frequency of the magnetic pole (n_1). The deviation in the slipping is obtained mainly at change in the amplitude at the supply voltage of the active resistance of the rotor chain. The change in slip is achieved mainly by changing the amplitude of the supply voltage. (Duranay, Z. B., Guldemir, H., & Tuncer, S.,2020).

A large application is found in the regulation of the speed of the induction motor by changing the frequency (f), which changes the synchronous speed. When the frequency is reduced to reduce the speed while voltage is constant, the flux must be increased in order to keep the induced emf (E) constant. Increase in flux causes saturation. In order to avoid saturation, the flux need to be kept constant. This requires the voltage has to be reduced with the frequency. This V/f ratio needs to be kept same for all frequencies to obtain a flux which produces maximum torque (Duranay, Z. B., Guldemir, H., & Tuncer, S.,2020). In order not to deteriorate the characteristics of the induction motor during frequency regulation, it is necessary to maintain the value of the magnetic flux. When the flux decreases, the magnetic system of the machine is used inefficiently, and when it increases, the magnetizing current increases as a result of saturation.

The terminal voltage V , which varies directly with the flux and frequency, is calculated by the formula (Aashitosh Todkar , Shubham Dange , Ashwini Palkhe , Reshma Sargar , Rajendra Madake, 2017):

$$V \approx E = 4,44fN \Phi_m , \tag{2}$$

where N represents the number of turns in the winding per phase, Φ_m represents maximum value of the airgap flux.

According (2) the magnetic flux keeps constant if the following condition is met:

$$\frac{V}{f} = \text{const.}, \tag{3}$$

which takes place at an unchanging static moment.

At fan resistance torque, which occurs at constant power ($P = \text{const.}$) is necessary

$$\frac{V^2}{f} = \text{const.}, \tag{4}$$

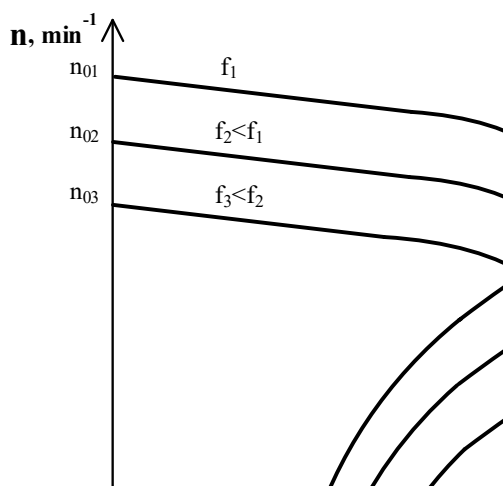

Fig. 1. Speed (n) vs Torque (T) at fixed v/f ratio

For other mechanical characteristics of the working mechanism, frequency regulation is carried out according to other laws. Most often, speed regulation is implemented by observing (3).

The speed-torque characteristic curves for constant V/f control are shown in Fig.1. A constant value of the critical torque can be maintained even at low frequencies if the voltage drop in the stator winding is compensated (i.e. the voltage drop is smaller than that of the current frequency). A very important advantage of frequency regulation is the smooth change in the speed of rotation of the IM over a wide range, with relatively small electrical losses.

For control of an induction motor through V/f method, the Matlab/Simulink program is used (<https://www.mathworks.com>). The motor research model is shown in Fig.2. The system consists of the following main blocks: PI controller, pulse – width modulator, inverter, induction motor.

The object of study is an induction motor with the following parameters determined by a Genetic Algorithm: Rated power 1,1kW; Supply frequency 50Hz; Rated voltage 380V; Rated speed 2830 min^{-1} ; Stator resistance 6,07 Ω ; Rotor resistance 5,69 Ω ; Stator inductance 0,01894 H; Rotor inductance 0,01894 H; Mutual inductance 0,484 H. The performance indices associated with induction motor such as speed (n), electromagnetic torque (T_e) are analysed to study the performance of IM.

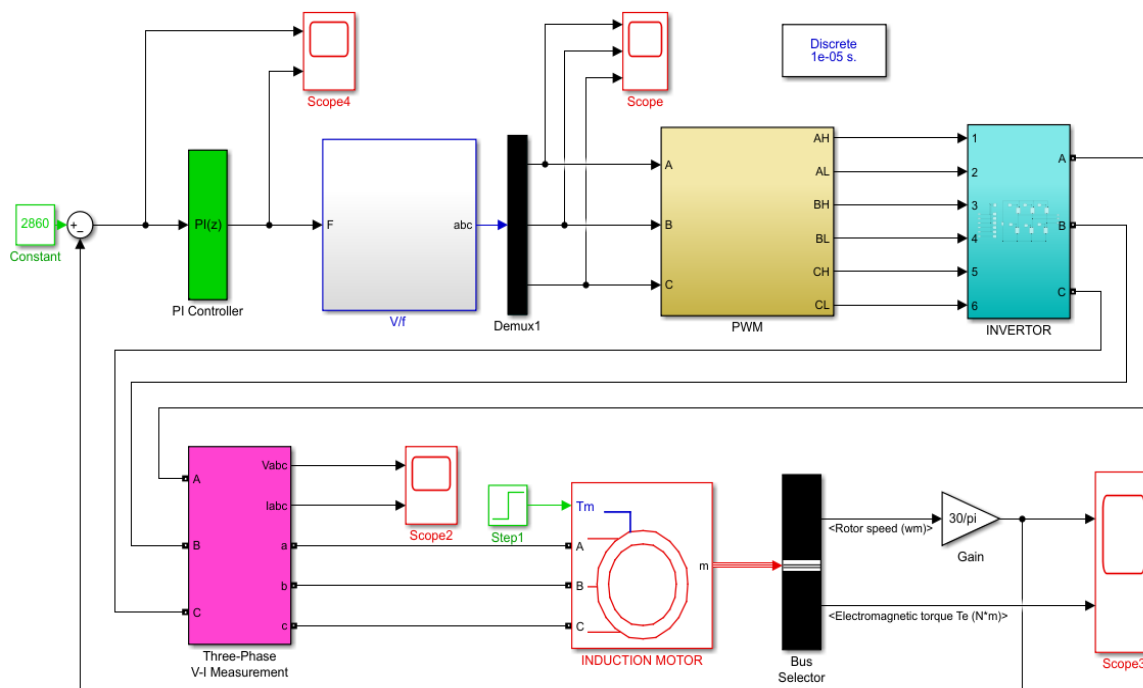

Fig.2. Closed system for V/f control of induction motor

The reference speed value at the entry of the system is compared with the actual one and the resulting error is fed to a PI controller. The signal at its output is the input for the V/f controller. It generates the control voltages, fig. 3. This voltage is then fed to the sinusoidal pulse width modulation block which generates the pulses to the voltage sourced inverter, such that the motor rotates at a speed equal to the reference speed, fig.4.

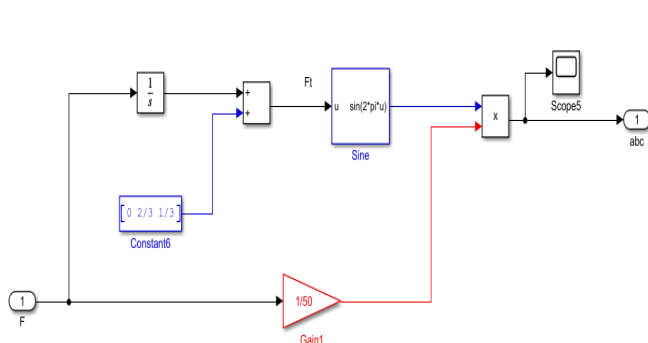

Fig.3. Block for V/f control of induction motor

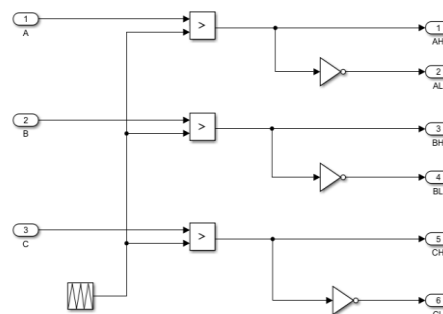

Fig.4. Pulse - width modulation block

The subsystem functions in a way that it produces the required pulse which activates the three phase inverter switches, namely; insulated-gate bipolar transistor (IGBT) and metal-oxide semiconductor field effect transistor (MOSFET), it uses pulse width modulation (PWM) technique which enables it compare a high frequency constant amplitude carrier wave (triangle wave) with modulating signal (sine wave) – fig.5.

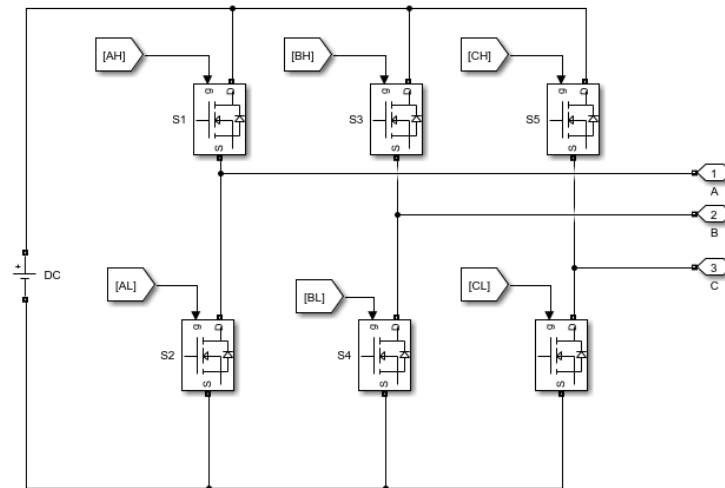

Fig.5. Inverter block

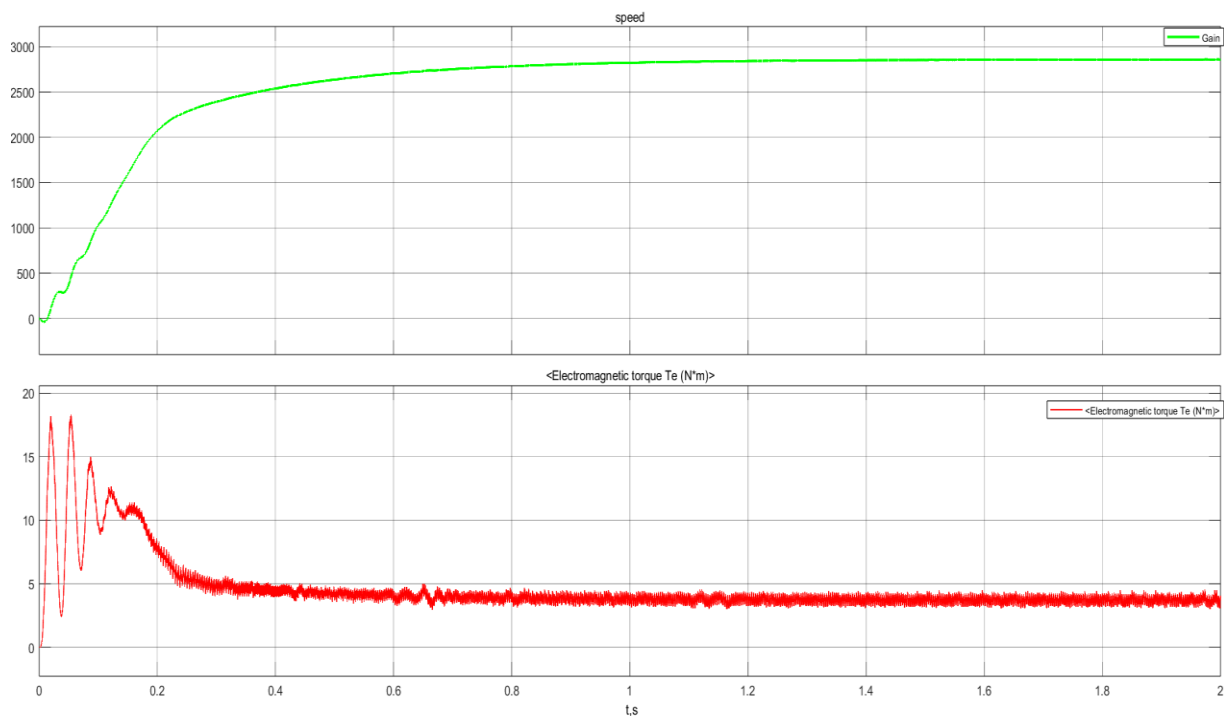

Fig.6. Transient processes of speed (n) and electromagnetic torque (Te)

The system was identified using the methods built into the software. First, the behaviour of the motor was analyzed and the transfer function of the control object was determined.

Then, using the automatic tuning feature in Matlab, the parameters of the PI controller were established. The parameters for tuning the PI controller are: $K_p=0,009$, $K_i=0,09$.

The speed transient process is shown in Fig. 6. The transition process of the speed is without overshoot with a duration of 1,4 s. The quality parameters meet the requirements of practice.

CONCLUSION

The article presents methods for regulating the rotational speed of induction motors. It describes the principle of the V/f method and the basic operation of the components used for its implementation.

A study was conducted on the control of an asynchronous motor using the V/f method in the Matlab/Simulink environment. Results were obtained for the rotational speed of the motor shaft and its electromagnetic torque. The processes fully meet the quality requirements for asynchronous motor control.

REFERENCES

Akhila, E., Praveen Kumar, N., Isha, T.B. (2016). *Fuzzy Logic and PI Controls in Speed Control of Induction Motor*. In: Suresh, L., Panigrahi, B. (eds) Proceedings of the International Conference on Soft Computing Systems. Advances in Intelligent Systems and Computing, vol 397. Springer, New Delhi.

O. E. - S. Mohammed Youssef (2018). *A New Open-Loop Volts/Hertz Control Method for Induction Motors*. Twentieth International Middle East Power Systems Conference (MEPCON), Cairo, Egypt, pp. 266-270.

Eko J. Akpama, Iwara E. Omini, Emmanuel E. Effiong, Raymond U. Ezenwosu (2020). *PID Speed Controlled Model of Induction Motor Using Simulink*. International Journal of Engineering Research And Management (IJERM), pp.24-28.

Olarinoye A. G., C. Akinropo, G. J. Atuman and Z. M. Abdullahi. (2019). *Speed Control of a Three Phase Induction Motor using a PI Controller*. 2nd International Conference of the IEEE Nigeria Computer Chapter (NigeriaComputConf), Zaria, Nigeria, pp. 1-7.

Varga, L., & Kuczmann, M. (2018). *Methods of Vector Control for Induction Motors*. Acta Technica Jaurinensis, 11(4), pp. 165–184.

Bharti R., M. Kumar and B. M. Prasad (2019). *V/F Control of Three Phase Induction Motor*. International Conference on Vision Towards Emerging Trends in Communication and Networking (ViTECoN), Vellore, India, pp. 1-4.

Hussein, A. T. (2021). *V/F Control of Three Phase Induction Motor Driven by VSI Based on SVPWM*. 2021 International Conference on Advance of Sustainable Engineering and its Application (ICASEA), Wasit, Iraq, pp. 49-53.

Duranay, Z. B., Guldemir, H., & Tuncer, S. (2020). *Implementation of a V/f Controlled Variable Speed Induction Motor Drive*. EMITTER International Journal of Engineering Technology, 8(1), 35-48.

Aashitosh Todkar , Shubham Dange , Ashwini Palkhe , Reshma Sargar , Rajendra Madake (2017). *Simulation based V/F speed control of three phase induction motor*. IJSDR - International Journal of Scientific Development and Research (www.IJSDR.org), ISSN:2455-2631, Vol.2, Issue 1, page no.80 - 87, January-2017.

<https://www.mathworks.com/matlabcentral/fileexchange/65675-v-f-speed-control-of-induction-motor>.